

# Russelectric

## AUTOMATIC TRANSFER SWITCHES

RMT Single Operator  
With Model 2000 Control



RMT

# Ruselectric Automatic Transfer Switches - Model RMT

- 2-, 3-, and 4-pole configuration
- Front accessible wiring
- Safe manual operator provides same quick-break, quick-make operation as electrical operator
- Simple electrical operator
- Positive mechanical and electrical interlocking
- Rapid arc quenching
- Quick-break, quick-make, high-speed transfer mechanism

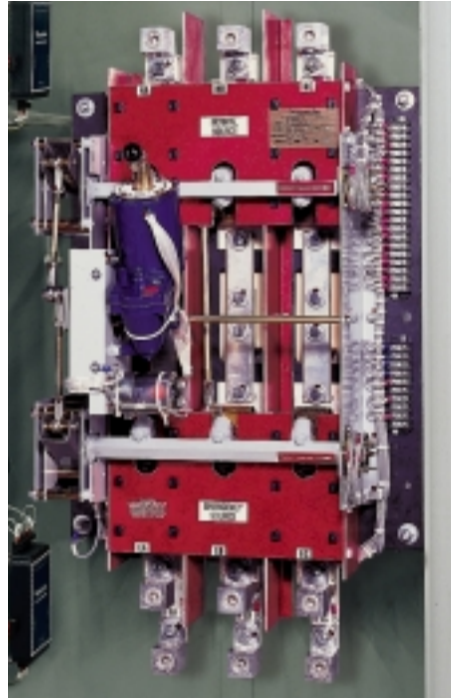

Ruselectric automatic transfer switches are modern, high-speed switching devices designed to transfer electrical loads from a normal power source to an emergency power source when voltage and/or frequency varies from preset limits, and to retransfer loads when normal power is restored.

The Ruselectric automatic transfer switch utilizes a high-speed, quick-break, quick-make, preloaded transfer that is accomplished by the use of a simple electrical operator. The operator is connected to the switch mechanism through precision self-aligning, aircraft-type ball joints which positively prevent misalignment. The entire line of Ruselectric transfer switches has been tested by Underwriters' Laboratories, Inc., and is listed under UL Standard 1008. Ruselectric subjects its transfer switches to the most comprehensive and demanding performance test program, with close-in and withstand short circuit ratings far surpassing the minimum requirements specified by UL-1008.

All transfer switches are thoroughly inspected both mechanically and electrically under simulated operating conditions before shipment.

All bus bars are fabricated copper and silver plated in accordance with UL and ANSI standards. Enclosures are fabricated with code gauge steel to meet UL and other applicable standards. Switches are packed and shipped in containers built to MIL specifications.

## The Industry's Highest 3-Cycle Closing and Withstand Ratings

Ruselectric transfer switches have the highest 3-cycle closing and withstand ratings of any switches available today (See chart).

These 3-cycle ratings mean that Ruselectric transfer switches are not restricted to specific manufacturer's circuit breakers, but are fully rated and labeled for use with any manufacturer's circuit breaker with instantaneous trip. These unrestricted ratings are extremely important, since they allow engineers to apply switches without problems of coordination with different breaker types.

### 3-Cycle Closing and Withstand Ratings RMS Symmetrical Amperes 480 VAC Based on Testing Under UL-1008

Switch Rating Amperes	Closing and Withstand
100-400	42,000
600-800	65,000
1000-1200	85,000
1600-4000	100,000

Underwriters' Laboratories, Inc., requires a transfer switch to be able to close in on the same amount of fault current as it can withstand before they allow it to be listed with a short circuit rating. In view of this, fuse protection becomes mandatory where extremely high short circuit current is available.

All Ruselectric transfer switches have closing and withstand rating of 200,000 amperes when coordinated with current limiting fuses.

## Microprocessor-Based Control System

The Ruselectric Model 2000 microprocessor-based control system is preprogrammed at the factory to control all of the operational functions of the automatic transfer switch, including standard accessories and optional accessories as specified by the purchaser.

The controller also senses the normal source and emergency source voltages, provides LED indicators to show whether the ATS is in the normal or emergency position, and also to confirm that the CPU is running.

A 20-character, 4-line LCD display and a 5 x 5 character tactile keyboard allows easy access to the control system, and is used to select items from main and submenus, to set up adjustable parameters, control the ATS, obtain operational status, and set up optional accessories.

The microprocessor board provides memory management, two asynchronous serial ports, battery backed real-time clock, and microprocessor supervisor (watchdog/power fail circuit).

Default setup information and calibration data are stored on nonvolatile EPROM. Changes to



default setup and calibration are stored on EEPROM.

A rechargeable NiCad battery provides 5 VDC power to the controller during the engine start timing cycle when no AC or DC power is available.

Self-diagnostics perform periodic checks of the memory, I/O, and communications systems, and invoke a software reset if required when an error is detected. A watchdog timer circuit invokes a hardware reset if program execution exceeds 1.6 seconds.

The system contains 3-phase, over/under voltage, over/under frequency, phase sequence detection, and phase differential monitoring for both normal and emergency sources.

The controller uses industry standard open architecture communication protocol for high speed serial communications via multidrop connection to other controllers and to a master terminal. The Accessory Setup and Service Screens allow accessory installation and changes to the system setup, calibration, and diagnostic functions. A password is required to limit access to qualified and authorized personnel.

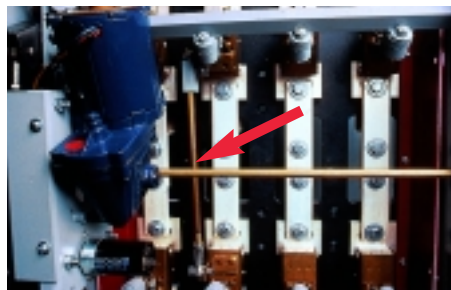

## Positive Mechanical and Electrical Interlocking

A rugged mechanical interlock between the normal and emergency contacts which positively prevents both sources from being closed simultaneously. The switching mechanism positively prevents a sustained neutral position, either electrically or mechanically, during normal operation with either source available.

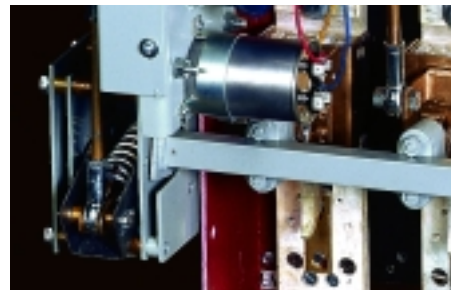

## Quick-Break, Quick-Make, High-Speed, Preloaded Transfer

During transfer, the contact mechanism is securely locked in position until the overcenter position is reached. The preloaded springs then instantaneously open the closed contacts (quick-break) and instantaneously close the open contacts (quick-make) with a momentary break in between. The quick-break feature provides for full arc interruption, under maximum voltage and amperage, in less than one-half cycle. This considerably reduces contact erosion and increases the useful life of the switch.

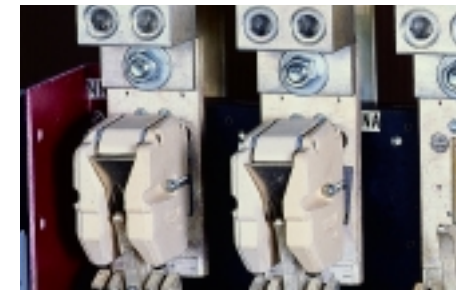

## Rapid and Reliable Arc Quenching

The current interrupting chamber of the Ruselectric transfer switch consists of parallel steel plates partially surrounding the contacts and enclosed by an insulator. When the contacts open, the arc drawn induces a magnetic field which splits the arc into a series of smaller arcs. The plates also conduct heat away from the arc.



## Safe Manual Operator

The manual operator transfers the switch with the same instantaneous contact opening and contact closing speed as the electrical operator. The switching mechanism, whether electrically or manually actuated, uses the preloaded transfer principle that precludes the possibility of a flashover or heavy arcing.

## External Manual Operation

Optional external manual operator provides manual operation of the switch with the protection of a fully closed enclosure door.

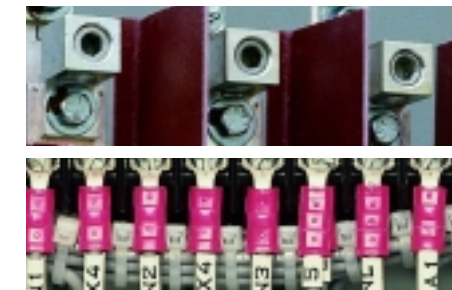

## Front Connected Control Components and Wiring

Control components and wiring can be replaced without removing the transfer switch from its enclosure.

Tracing of the electrical circuitry is simplified by the neatly arranged, front-connected, flame retardant, 600-volt SIS switchboard wiring. Heavy-duty control components and contacts are provided to handle switching requirements.

All wiring connections are made using crimped terminals and sleeve-type marking labels.

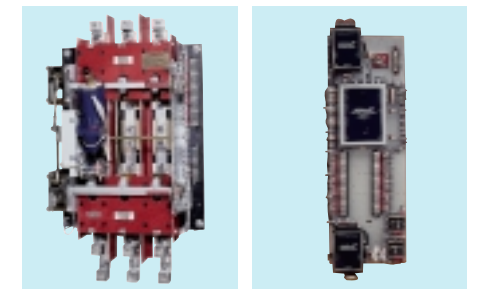

## Vertical-Type "VS" Switchboard Construction

Control plates are available in narrow widths for installation in switchboard cubicles with either front or rear terminals and/or bus tabs. Narrow widths are available to fit motor control center requirements (19 inches for capacities to 800 amperes 3-pole). Special arrangements are also available.

# Dimensions Open Style Switches

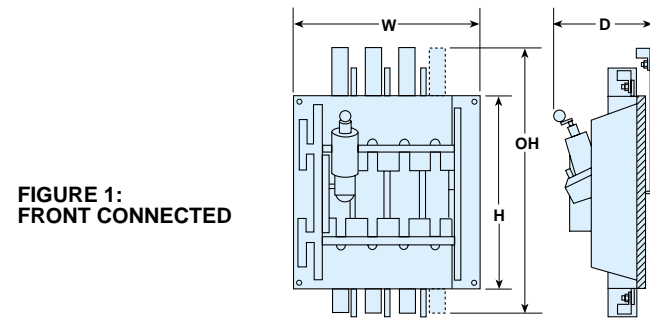

FIGURE 1: FRONT CONNECTED

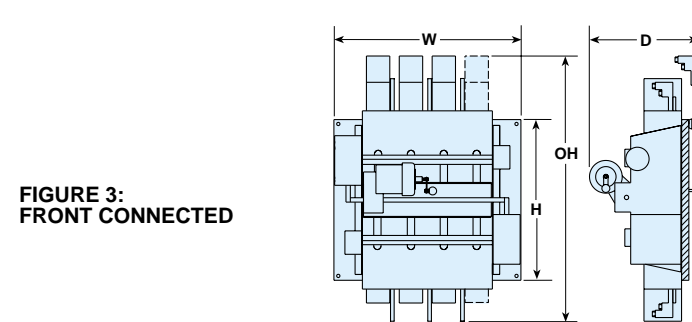

FIGURE 3: FRONT CONNECTED

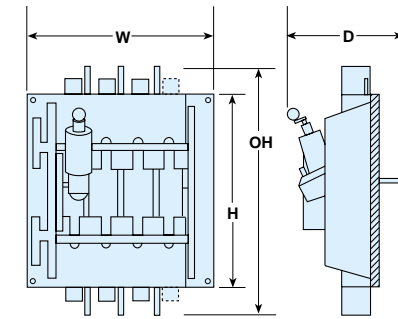

FIGURE 2: REAR CONNECTED

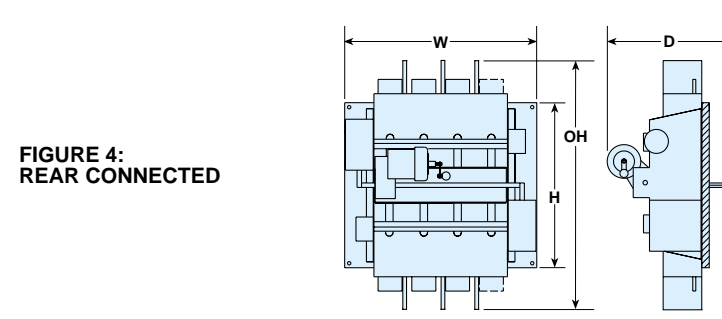

FIGURE 4: REAR CONNECTED

### OPEN TYPE 100-800 AMP

Switch Rating amps	Switched Poles	Front Connected (Figure 1) Dimensions inches				Rear Connected (Figure 2) Dimensions inches				Approx. Shipping Weight <sup>3</sup> pounds
		H	W	D	OH	H	W	D	OH	
100	2 or 3	19.00				19.00				390
	4	24.00	24.00	12.75	31.500	24.00	24.00	13.625	31.50	440
150	2 or 3	19.00				19.00				400
	4	24.00	24.00	12.75	31.500	24.00	24.00	13.625	31.50	450
260	2 or 3	19.00				19.00				420
	4	24.00	24.00	12.75	35.062	24.00	24.00	13.625	31.50	470
400	2 or 3	19.00				19.00				430
	4	24.00	24.00	12.75	35.062	24.00	24.00	13.625	31.50	480
600	2 or 3	19.00				19.00				440
	4	24.00	24.00	12.75	35.062	24.00	24.00	13.625	31.50	490
800	2 or 3	19.00				19.00				450
	4	24.00	24.00	12.75	35.062	24.00	24.00	13.625	31.50	500

### OPEN TYPE 1000-3000 AMP

Switch Rating amps	Switched Poles	Front Connected (Figure 3) Dimensions inches				Rear Connected (Figure 4) Dimensions inches				Approx. Shipping Weight <sup>3</sup> pounds
		H	W	D	OH	H	W	D	OH	
1000	2 or 3	27.00				27.00				550
	4	27.50	32.00	22.375	45.375	27.50	32.00	24.00	41.5	700
1200	2 or 3	27.00				27.00				585
	4	27.50	32.00	22.375	45.375	27.50	32.00	24.00	41.5	735
1600	2 or 3	27.00				27.00				625
	4	27.50	32.00	22.375	45.375	27.50	32.00	24.00	41.5	775
2000	2 or 3	27.00				27.00				675
	4	27.50	32.00	22.375	45.375	27.50	32.00	24.00	41.5	815
2500	2 or 3	27.00				27.00				700
	4	27.50	32.00	26.250	45.375	27.50	32.00	25.00	41.5	830
3000	2 or 3	36.00				36.00				750
	4	27.50	44.00	26.250	45.375	27.50	44.00	25.00	41.5	900

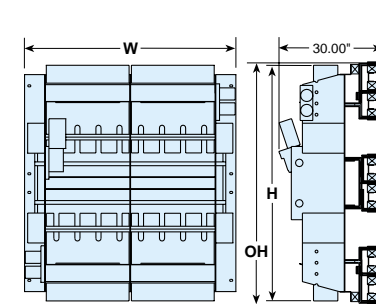

### OPEN TYPE

Switch Rating amp	Switched Poles	Dimensions inches			Approx. Shipping Weight <sup>2</sup> pounds
		W	H	OH	
4000	3	45.25	64	65.25	2400
	4	56.50	64	65.25	2900

**CONTROL COMPONENTS MOUNTING PLATES**

7.00" Maximum Over Control Devices

**FOR MOUNTING ABOVE OR BELOW TRANSFER SWITCH**

100 - 3000 Amp Relay Plate (VS Configuration)

Switch Rating amps	Poles	W	H
100-800	3	19"	22"
100-800	4	24"	22"
1000-2500	3	27"	19"
1000-2500	4	32"	19"
3000	3	36"	14"
3000	4	44"	14"

**FOR MOUNTING ABOVE TRANSFER SWITCH**

4000 Amp Relay Plate (VS Configuration)

Switch Rating amps	Poles	W
4000	3	45.25"
4000	4	56.50"

**FOR MOUNTING BESIDE TRANSFER SWITCH**

100 - 4000 Amp Relay Plate (NEMA Configuration)

Switch Rating amps	W
100-260	7.5"
400-800	7.5"
1000-4000	12"

### Design Considerations

- Control components mounting plate required with all switches.
- Switch can be furnished with load connections at top or bottom.
- Switches are furnished with normal connection at top and emergency at bottom. Positions may be reversed if desired.
- Switch is designed for mounting in a nonventilated enclosure.
- Standard wiring harness is 6 feet. Other lengths on request.
- Fourth pole neutral on all 4-pole switches.
- Lugs furnished on front-connected switches only. Lug quantity and size data identical to corresponding enclosed switch lug data.

# Dimensions Enclosed Switches

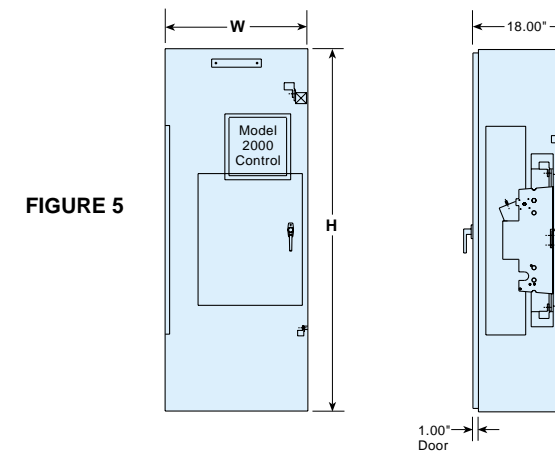

FIGURE 5

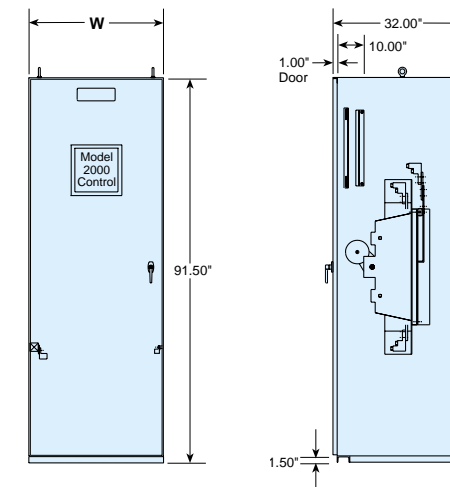

FIGURE 6

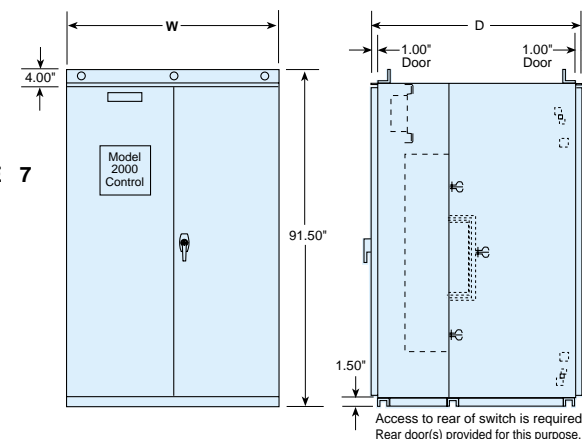

FIGURE 7

### Guide to Russelectric RMT Catalog Numbering System

Choose one from each column.

Prefix	Switch Size	No. of Poles	Phase Sensing	Configuration*
RMT	100	2	(Automatic 2 Pole) B	(Open NEMA Style) Leave blank
	150			(Vertical Style) VS
	260			(Enclosure Wall Mounted) E
	400			(Enclosure Free Standing) EF
	600	3	(Automatic 3 or 4 Pole) C	(Open NEMA Style) Leave blank
	800			(Vertical Style) VS
	1000			(Enclosure Wall Mounted) E
	1200			(Enclosure Free Standing) EF
	1600	4	(Automatic 3 or 4 Pole) C	(Open NEMA Style) Leave blank
	2000			(Vertical Style) VS
	2500			(Enclosure Wall Mounted) E
	3000			(Enclosure Free Standing) EF
4000				

### Example:

Single operator, 100 amp, 4 pole, freestanding enclosure = RMT1004CE

\*1000-4000 amp Automatic Transfer Switches *must* be freestanding.

### 100-800 AMP ENCLOSED TYPE (FIGURE 5)

Switch Rating amps	Switched Poles	Dimensions inches		Lug Size Normal, Emergency, Load per Phase and Neutral <sup>1</sup>	Approximate Shipping Weight <sup>2</sup> pounds
		W	H		
100	2 or 3	26	44.00	(1) #14 to 1/0	490
	4	31	44.00		565
150	2 or 3	26	44.00	(1) #6 to 250 MCM	500
	4	31	44.00		575
260	2 or 3	26	66.00	(1) #4 to 600 MCM or (2) 1/0 to 250 MCM	520
	4	31	66.00		595
400	2 or 3	26	66.00	(1) #4 to 600 MCM or (2) 1/0 to 250 MCM	530
	4	31	66.00		605
600	2 or 3	26	66.00	(2) #4 to 500 MCM	540
	4	31	66.00		615
800	2 or 3	26	66.00	(2) #4 to 600 MCM or (4) 1/0 to 250 MCM	550
	4	31	66.00		625

### 1000-3000 AMP ENCLOSED TYPE (FIGURE 6)

Switch Rating amps	Switched Poles	Dimensions inches		Lug Size Normal, Emergency, Load per Phase and Neutral <sup>1</sup>	Approximate Shipping Weight <sup>2</sup> pounds
		W	D		
1000	2 or 3	32	32	(3) #2 to 600 MCM	1025
	4	36	32		1250
1200	2 or 3	32	32	(3) #2 to 600 MCM	1060
	4	36	32		1285
1600	2 or 3	32	32	(4) #2 to 600 MCM	1100
	4	36	32		1325
2000	3	32	32	(5) #2 to 600 MCM	1150
	4	36	32		1365
2500	3	32	36	(6) #2 to 600 MCM	1205
	4	36	36		1410
3000	3	40	40	(8) #4 to 600 MCM	1265
	4	48 <sup>4</sup>	40		1480

### 4000 AMP ENCLOSED TYPE (FIGURE 7)

Switch Rating amps	Switched Poles	Dimensions inches		Lug Size Normal, Emergency, Load per Phase and Neutral <sup>1</sup>	Approximate Shipping Weight <sup>2</sup> pounds
		W	D		
4000	3	51.0	60.0	(10) #4 to 600 MCM	3100
	4	60.0	60.0		3600

The layout drawings are for layout purposes only and are subject to change without notice. For details on lug spacing, etc., certified prints can be furnished on request. See Pages 6 and 7 for complete list of accessories.

### Notes:

- Ground lugs provided to NEC. All lugs are mechanical type suitable for copper or aluminum cable.
- Weights shown are approximate and may vary according to number and types of accessories.
- Weights shown are approximate and includes control components mounting plate.
- Double door configuration (See Figure 7).

- "A" dimension varies with height of switch base. Consult factory for details.
- 38" height is for standard accessory package and may increase with number of accessories specified. Consult factory for details.

# Automatic Transfer Switch Accessory List

This is a condensed list. Full detail on accessories is included in the specifications. See pages 7-8. **Accessories shown in bold face are available through software within the microprocessor control.** Accessories shown in light face are optional hardware accessories and must be specified with order.

- STD Under voltage and frequency sensing of normal source.**
- STD Under voltage and frequency sensing of emergency source.**
- 1d Time delay to override momentary normal source power outages to delay engine start signal.**
- 1dx Time delay to override momentary normal source power outages to delay transfer switch operation.**
- 2a Time delay on retransfer to normal (do not use with 6a).**
- 2b Time delay on transfer to emergency.**
- 2c Time delay to override momentary normal source power outages to delay engine start signal and transfer switch operation (do not use with a two utility source switch).
- 2e Engine overrun to provide unloaded engine operation after retransfer to normal.**
- 4b Over voltage and frequency sensing of normal source.**
- 5a Keypad initiated load test function to simulate a normal source power failure (maintain type).**
- 5al Lever-operated switch same as 5a.
- 5at Toggle-operated switch same as 5a.
- 5ak Key-operated switch same as 5a.
- 5c Provisions for remote load test switch to simulate a normal source power failure. (Requires a closed contact signal.)**
- 5d Keypad initiated override function to bypass the automatic transfer switch controls so that the transferred switch will remain indefinitely connected to the emergency power source regardless of the condition of the normal power source.**
- 5dl Lever-operated switch same as 5d.
- 5dt Toggle-operated switch same as 5d.
- 5dk Key-operated switch same as 5d.
- 6a Push button retransfer to normal.
- 6b Keypad initiated bypass time delay on retransfer to normal source.**
- 6bp Push button to bypass time delay on retransfer to normal.
- 7 Contact to close on failure of normal source to initiate engine starting or other customer functions.**
- 7x Normal source available. Output relay contacts wired to terminal strip.
- 8 Contact to open on failure of normal source for customer functions.**
- 9a Green LED to indicate switch in normal position.**
- 9ax Amber LED to indicate normal power available.
- 9b Red LED to indicate switch in emergency position.**
- 9bx Amber LED to indicate emergency power available.
- 10a 12-Volt D.C. battery charger.
- 10b 24-Volt D.C. battery charger.
- 11a Plant exerciser to automatically exercise generating plant without load transfer.**
- 11b Plant exerciser to simulate a normal power failure and transfer the load to the generators.**
- 11c Plant exerciser to automatically exercise generation plant, with or without load.**
- 11cl Plant exerciser, same as 11c but with lever switch.
- 11d Plant exerciser, same as 11c but with 2 position exercise on/off switch.
- 11dk Plant exerciser, same as 11d but with key switch.
- 12a Four-position selector switch with "load test", "automatic", "off", and "hand crank" positions.
- 12b Two-position selector switch to select either automatic or manual retransfer to normal operation, with push button retransfer to normal.
- 12c Keypad initiated function to select either automatic or manual transfer switch operation. Keypad initiated transfer to emergency or retransfer to normal, while in manual mode.**
- 12c1 Same as 12c but with external lever-operated switch and external transfer push-buttons**
- 12x Keypad initiated function to select either "No-Commit" or "Commit" to transfer operation in the event of a normal power failure.**
- 12xl Two-position lever operated selector switch same as 12x.

- 12xk Two-position key operated selector switch same as 12x.
- 14a Auxiliary contact closed in normal position.
- 14b Auxiliary contact closed in emergency position.
- 14x Auxiliary contact to indicate ATS is in the center "off" position.
- 16t Toggle-operated switch to disconnect the engine starting contact (Engine lockout).
- 16l Lever-operated switch same as 16t.
- 16k Key-operated switch to disconnect the engine starting contact (Engine lockout).
- 17 Circuit for area protection.**
- 18a Ammeter to read current in phase two only of load circuit.
- 18b Ammeter with four-position selector switch marked off-1-2-3 to read current in all three phases of load circuit.
- 19a Voltmeter connected across phase one and phase three of the emergency source.
- 19b Voltmeter with four-position selector marked off 1-2, 2-3, 3-1. Three phase type to read phase-to-phase voltage of the emergency source.
- 19bd Digital voltmeter three phase type reading phase-to-phase voltage & frequency on the normal and the emergency source.**
- 19c Voltmeter with seven-position selector switch marked 3-1, 2-3, 1-2, off, 1, 2, 3. Three phase type to read phase-to-phase and phase-to-neutral voltage of emergency source.
- 21x Emergency source available. Output relay contacts wired to terminal strip.
- 22 20A, line-to-line, three phase fused circuit energized from emergency source of power.
- 22x 20A, fused circuit energized from normal source.
- 22xx 20A, line-to-line, three phase fused circuit energized from the normal source of power.
- 22xxx 20A, line-to-line, three phase fused circuit connected to the load side of switch.
- 23a (2) Form "C" contacts that change state milliseconds prior to transfer in either direction and reset 0-9999 seconds (adjustable) after transfer.
- 23b (2) Form "C" contacts that change state 0-9999 seconds (adjustable) before transfer in either direction. These contacts reset immediately after transfer.
- 23c (2) Form "C" contact that change state 0-9999 seconds (adjustable) before transfer in either direction and reset 0-9999 seconds (adjustable) after transfer.
- 26 Over voltage and frequency sensing of emergency source.**
- 28 Audible alarm to indicate switch in emergency position with alarm silence circuit and pilot light to indicate that alarm has been silenced.
- THS/ST1 Thermostat and strip heater assembly.
- BTR Block transfer function energized by 24VDC signal to allow transfer-to-emergency, with keypad initiated bypass block transfer-to-emergency.**
- BTRK Block transfer function energized by 24VDC signal to allow transfer-to-emergency. Supplied with two-position spring-return keyed-operated switch to bypass block transfer-to-emergency and is used for manual operation.
- LSR Load shed function energized by 24VDC signal to disconnect the load from the emergency source when an overload condition occurs.**
- LTR Load test function energized by 24VDC signal to simulate a normal power failure.**
- PSR Peak shave function energized by 24VDC signal. This function will start the emergency generator and transfer the ATS to the emergency source, reducing the utility supply to the building. After this peak shave signal is removed, the ATS will retransfer to the normal supply bypassing the retransfer time delay.**
- PRR Keypad initiated function to detect changes in phase sequence of normal and emergency sources.**
- EMO External manual operator.
- MDS Disconnect switch to disable the ATS electrical operator when placed in the disconnect position. Key operated switch.

\* Select 11a, 11b, or 11c

# RMT Specifications

## PART 1 — GENERAL

### 1.01 WORK INCLUDED

#### A. Automatic Transfer Switches

### 1.02 SYSTEM

A. Furnish the automatic transfer switches to automatically transfer between the normal and emergency power source.

### 1.03 APPLICABLE STANDARDS

A. The automatic transfer switches covered by these specifications shall be designed, tested, and assembled in strict accordance with all applicable standards of ANSI, U.L., IEEE and NEMA.

### 1.04 SUBMITTALS

A. Manufacturer shall submit shop drawings for review, which shall include the following, as a minimum:

1. Descriptive literature
2. Plan, elevation, side, and front view arrangement drawings, including overall dimension, weights and clearances, as well as mounting or anchoring requirements and conduit entrance locations.
3. Schematic diagrams.
4. Wiring diagrams.
5. Accessory list.

## PART 2 — PRODUCTS

### 2.01 ACCEPTABLE MANUFACTURERS

#### A. Russelectric

### 2.02 CONSTRUCTION

#### A. General

1. The automatic transfer switch shall be furnished as shown on the drawings. Voltage and continuous current ratings and number of poles shall be as shown.
2. On 3-phase, 4-wire systems, in which switched neutral is required, a true 4-pole switch shall be supplied with all four electrically and mechanically identical poles mounted on a common shaft. The continuous current rating and the closing and withstand rating of the fourth pole shall be identical to the rating of the main poles.
3. The transfer switch shall be mounted in a NEMA 1 enclosure, unless otherwise indicated. Enclosures shall be fabricated from 12 gauge steel. The enclosure shall be sized to exceed minimum wire bending space required by UL 1008.
4. The transfer switch shall be equipped with an internal welded steel pocket, housing an operations and maintenance manual.
5. The transfer switch shall have both top and bottom cable access.
6. The main contacts shall be visible for inspection without any major disassembly of the transfer switch.
7. The main contacts shall be capable of being replaced without removing the power cables.
8. All bolted bus connections shall have Belleville compression type washers.
9. When a solid neutral is required, a fully rated bus bar with required AL-CU neutral lugs shall be provided.
10. Control components and wiring shall be front accessible. All control wires shall be multiconductor 18 gauge 600 volt SIS switchboard type point to point harness. All control wire terminations shall be identified with tubular sleeve-type markers.
11. The switch shall be equipped with 90° C rated copper/aluminum solderless mechanical type lugs.
12. The complete transfer switch assembly shall be factory tested to ensure proper operation and compliance with the specification

requirements. A copy of the factory test report shall be available upon request.

#### B. Automatic Transfer Switch

1. The transfer switch shall be double throw, actuated by a single electrical operator momentarily energized, and connected to the transfer mechanism by a simple over center type linkage. Total transfer time shall not exceed one half second

2. The normal and emergency contacts shall be positively interlocked mechanically and electrically to prevent simultaneous closing. Main contacts shall be mechanically locked in both the normal and emergency positions without the use of hooks, latches, magnets, or springs, and shall be silver-tungsten alloy. Separate arcing contacts with magnetic blowouts shall be provided on all transfer switches. Interlocked, molded case circuit breakers or contactors are not acceptable.

3. The transfer switch shall be equipped with a safe external manual operator, designed to prevent injury to operating personnel. The manual operator shall provide the same contact to contact transfer speed as the electrical operator to prevent a flashover from switching the main contacts slowly. The external manual operator shall be safely operated from outside of the transfer switch enclosure while the enclosure door is closed.

#### C. Automatic Transfer Switch Controls

1. The transfer switch shall be equipped with a microprocessor-based control system, to provide all the operational functions of the automatic transfer switch. The controller shall have two asynchronous serial ports. The controller shall have a real time clock with NiCad battery back-up.
2. The CPU shall be equipped with self diagnostics which perform periodic checks of the memory I/O and communication circuits, with a watchdog/power fail circuit.
3. The controller shall use industry standard open architecture communication protocol for high speed serial communications via multidrop connection to other controllers and to a master terminal with up to 4000 ft of cable, or further, with the addition of a communication repeater. The serial communication port shall be RS422/485 compatible.
4. The serial communication port shall allow interface to either the manufacturers or the owners furnished remote supervisory control.
5. The controller shall have password protection required to limit access to qualified and authorized personnel.
6. The controller shall include a 20-character LCD display with a keypad, which allows access to the system.
7. The controller shall include three phase over/under voltage, over/under frequency, phase sequence detection and phase differential monitoring on both normal and emergency sources.
8. The controller shall be capable of storing the following records in memory for access either locally or remotely:
  - a. Number of hours transfer switch is in the emergency position (total since record reset).
  - b. Number of hours emergency power is available (total since record reset)

- c. Total transfer in either direction (total since record reset).
- d. Date, time, and description of the last four source failures.
- e. Date of the last exercise period.
- f. Date of record reset.

#### D. Sequence of Operation

1. When the voltage on any phase of the normal source drops below 80% or increases to 120%, or frequency drops below 90%, or increase to 110%, or 20% voltage differential between phases occurs, after a programmable time delay period of 0-9999 seconds factory set at 3 seconds to allow for momentary dips, the engine starting contacts shall close to start the generating plant.
  2. The transfer switch shall transfer to emergency when the generating plant has reached specified voltage and frequency on all phases.
  3. After restoration of normal power on all phases to a preset value of at least 90% to 110% of rated voltage, and at least 95% to 105% of rated frequency, and voltage differential is below 20%, an adjustable time delay period of 0-9999 seconds (factory set at 300 seconds) shall delay retransfer to allow stabilization of normal power. If the emergency power source should fail during this time delay period, the switch shall automatically return to the normal source.
  4. After retransfer to normal, the engine generator shall be allowed to operate at no load for a programmable period of 0-9999 seconds, factory set at 300 seconds.
- #### E. Automatic Transfer Switch Accessories
1. Programmable three phase sensing of the normal source set to pickup at 90% and dropout at 80% of rated voltage and overvoltage to pickup at 120% and dropout out at 110% of rated voltage. Programmable frequency pickup at 95% and dropout at 90% and over frequency to pickup at 110% and dropout at 105% of rated frequency. Programmable voltage differential between phases, set at 20%, and phase sequence monitoring.
  2. Programmable three phase sensing of the emergency source set to pickup at 90% and dropout at 80% of rated voltage and overvoltage to pickup at 120% and dropout out at 110% of rated voltage. Programmable frequency pickup at 95% and dropout at 90% and over frequency to pickup at 110% and dropout at 105% of rated frequency. Programmable voltage differential between phases set at 20%, and phase sequence monitoring.
  3. Time delay for override of momentary normal source power outages (delays engine start signal and transfer switch operation). Programmable 0-9999 seconds. Factory set at 3 seconds, if not otherwise specified.
  4. Time delay on retransfer to normal, programmable 0-9999 seconds, factory set at 300 seconds if not otherwise specified, with overrun to provide programmable 0-9999 second time delay, factory set at 300 seconds, unloaded engine operation after retransfer to normal.
  5. Time delay on transfer to emergency, programmable 0-9999 seconds, factory set at 3 seconds.

6. A maintained type load test switch shall be included to simulate a normal power failure. Keypad initiated.
7. A remote type load test circuit shall be included to simulate a normal power failure. Remote switch initiated.
8. A time delay bypass on retransfer to normal shall be included. Keypad initiated.
9. Contact, rated 10 Amps 30VDC, to close on failure of normal source to initiate engine starting.
10. Contact, rated 10 Amps 30VDC, to open on failure of normal source for customer functions.
11. Light emitting diodes shall be mounted on the microprocessor panel to indicate: switch is in normal position, switch is in emergency position and controller is running.
12. A plant exerciser shall be provided with (10) 7 day events, programmable for any day of the week and (24) calendar events, programmable for any month/day, to automatically exercise generating plant programmable in one minute increments. Also include selection of either "no load" (switch will not transfer) or "load" (switch will transfer) exercise period. Keypad initiated.
13. Provision to select either "no commit" or "commit" to transfer operation in the event of a normal power failure shall be included. In the "no commit position," the load will transfer to the emergency position unless normal power returns before the emergency source has reach 90% of it's rated values (switch will remain in normal). In the "commit position" the load will transfer to the emergency position after any normal power failure. Keypad initiated.
14. Two auxiliary contacts rated 10 Amp, 120VAC (for switches 100 to 800 amps) 15 amp, 120VAC (for switches 1000 to 4000 amps), shall be mounted on the main shaft, one closed on normal, the other closed on emergency. Both contacts will be wired to a terminal strip for ease of customer connections.
15. A three phase digital LCD voltage readout, with 1% accuracy shall display all three separate phase to phase voltages simultaneously, for both the normal and emergency source.
16. A digital LCD frequency readout with 1% accuracy shall display frequency for both normal and emergency source.
17. An LCD readout shall display normal source and emergency source availability.

**F. Specifiers Notes: The following accessories shall be available by simple activation, via the keypad, if required.**

1. (2) time delay contacts that open simultaneously just (milliseconds) prior to transfer in either direction. These contacts close after a time delay upon transfer. Programmable 0-9999 seconds after transfer.
2. (2) Form "C" contacts that open simultaneously before transfer in either direction and reclose instantaneously after transfer.
3. (2) Form "C" contacts that open simultaneously 5 seconds before transfer in either direction and reclose 5 seconds after transfer.
4. A block transfer function shall be included, energized from a 24VDC signal, to prevent transfer to emergency.
5. A load shed function shall be included, energized from a 24VDC signal, to disconnect the load from the emergency source when an overload condition occurs.
6. A peak shave function shall be included, energized from a 24VDC signal. This function will start the emergency generator and transfer the ATS to the emergency source reducing the utility supply to the building. After the peak shave signal is removed, the transfer switch will retransfer to the normal supply, bypassing the retransfer time delay.

**G. Approval**

1. As a condition of approval, the manufacturer of the automatic transfer switches shall verify that their switches are listed by Underwriters Laboratories, Inc., Standard UL-1008 with 3 cycle short circuit closing and withstand as follows:

**RMS Symmetrical Amperes 480 VAC**

<i>Switch Rating Amperes</i>	<i>Closing and Withstand</i>
100-400	42,000
600-800	65,000
1000-1200	85,000
1600-4000	100,000

2. During the 3-cycle closing and withstand tests, there shall be no contact welding or damage. The 3-cycle tests shall be performed without the use of current limiting fuses. The test shall verify that contact

separation has not occurred, and there is contact continuity across all phases. Test procedures shall be in accordance with UL-1008, and testing shall be certified by Underwriters' Laboratories, Inc.

3. In addition to the 3-cycle closing and withstand ratings, the automatic transfer switch shall have closing and withstand current rating of 200,000 amperes when coordinated with current limiting fuses.
4. When conducting temperature rise tests to UL-1008, the manufacture shall include post-endurance temperature rise tests to verify the ability of the transfer switch to carry full rated current after completing the overload and endurance tests.
5. The microprocessor controller shall meet the following requirements:
  - Storage conditions—25° C to 85° C
  - Operation conditions—20° C to 70° C ambient
  - Humidity—0 to 99% relative humidity, noncondensing
  - Capable of withstanding infinite power interruptions
  - Surge withstand per ANSI/IEEE C37.90-1989
6. Manufacturer shall provide copies of test reports upon request.

**H. Manufacturer**

1. The transfer switch manufacturer shall employ a nationwide factory-direct, field service organization, available on a 24-hour a day, 365 days a year, call basis.
2. The manufacture shall include an 800 telephone number, for field service contact, affixed to each enclosure.
3. The manufacturer shall maintain records of each transfer switch, by serial number, for a minimum 20 years.

**PART 3—EXECUTION**

**3.01 INSTALLATION**

- A. Automatic Transfer Switches shall be provided with adequate lifting means for ease of installation of wall or floor mounted enclosures.
- B. Provide access and working space as indicated or as required.

**3.02 ADJUSTMENTS**

- A. Tighten assembled bolted connections with appropriate tools to manufacturer's torque recommendations prior to first energization.



South Shore Park, Hingham, MA 02043-4387  
 TEL: 781 749-6000 ■ FAX: 781 749-4205  
 e-mail: marketing@russelectric.com